

HYDROCADE™ WATER BARRICADE SYSTEM

TL-3 Longitudinal Channelizing Device*



- 72"L x 32"H longitudinal channelizing device (182.9 cm L x 81.3 cm H)
- Unique stacking design allow for up to 50% more units per truckload
 - 200 units per truck, 8 units per pallet
- Durable construction, impact resistant
- Flat obstruction free side, position to eliminate pedestrian trip hazard
- Conforms to any roadway design
 - turns 90° and adjusts to curbs up to a 6° incline
- Connector pins snap onto barricade center for storage and transport
 - sturdy and tough pins, built with strength-enhancing channels
- Fill with 81 gallons of water for LCD deployable weight of 745 lbs.
 - every unit is leak tested
- Two forklift access areas
- Stacking lugs keep stacked units from sliding
- Light shelf for standard barricade light
- Accepts optional fence panels in place of connector pins
- Areas for retroreflective striped sheeting
 - 44" x 8" (111.8 cm x 20.3 cm) on both sides
- Standard in orange and white, custom colors available
- Crash tested for TL-3 MASH Acceptance, submitted to FHWA*
- Meets MUTCD Standards

**UP TO
50% MORE
PER TRUCK**

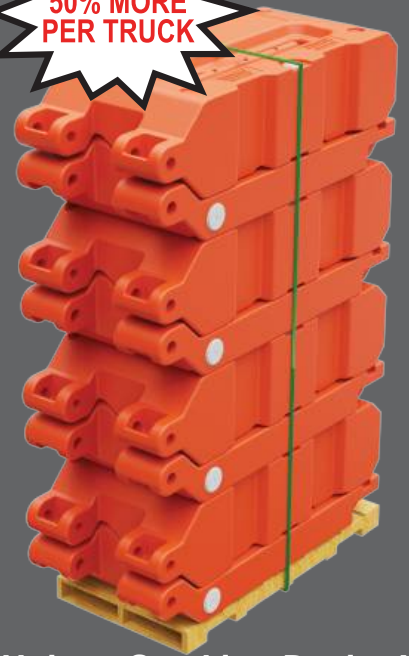

**Unique Stacking Design!
8 Units/Pallet
200 Units/Truck**

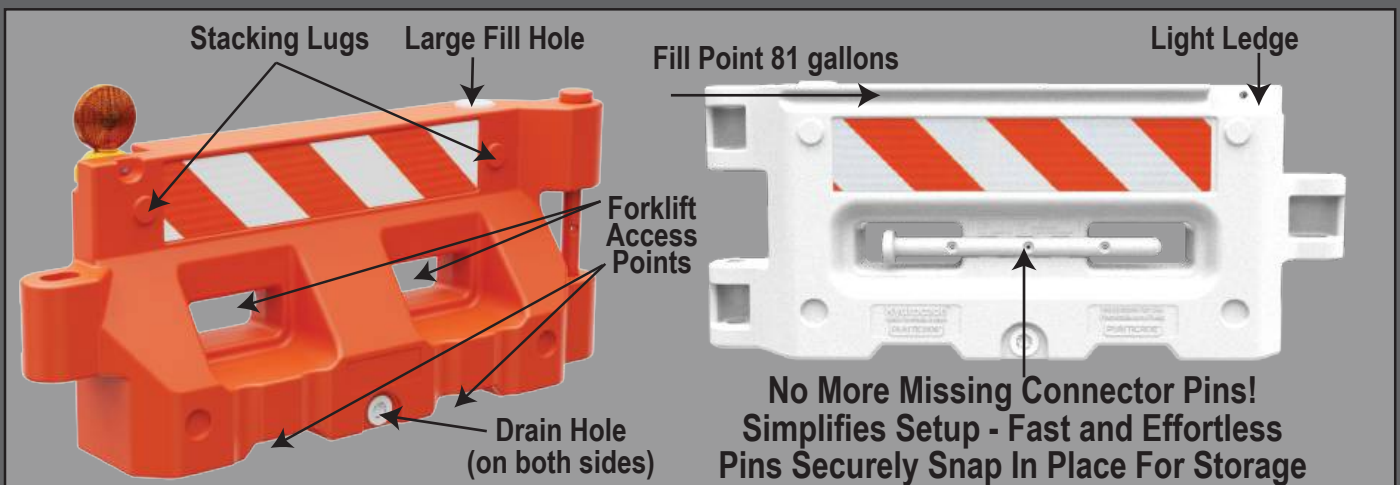

HYDROCADE™ WATER BARRICADE SYSTEM

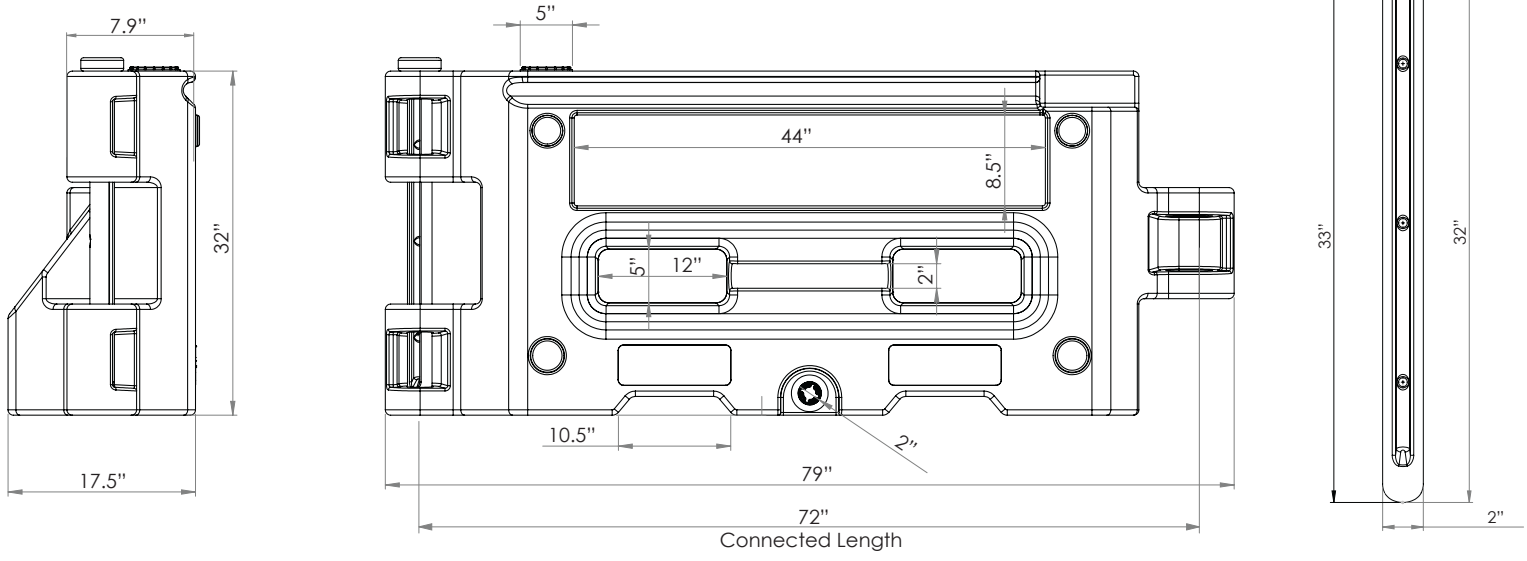

Galvanized Pipe 16 gauge

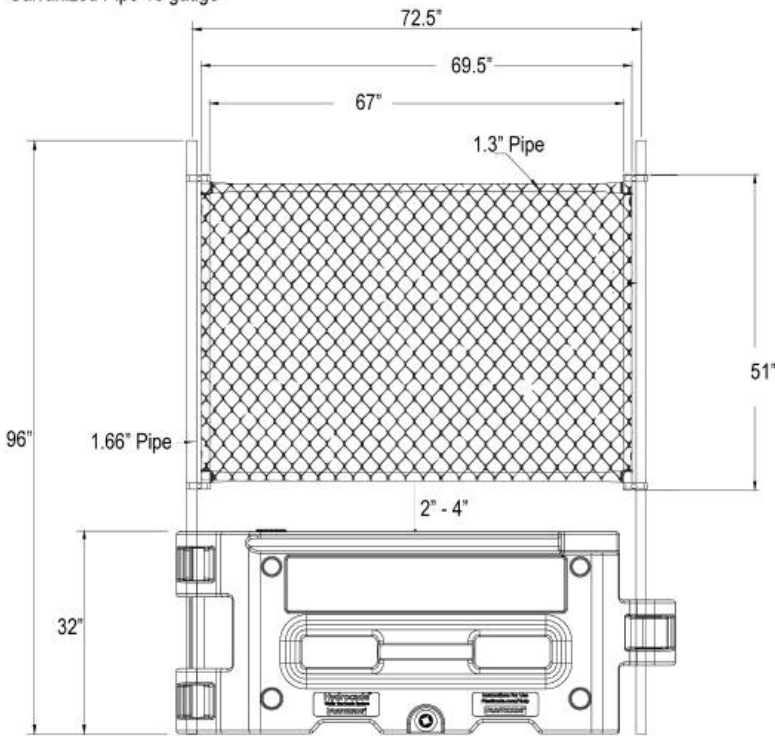

Specs

Composition	Medium density polyethylene
Dimensions	79" L x 17.5" W x 32" H 200.7 cm x 44.5 cm x 81.3 cm Top Width: 8" (20.32 cm)
Weight	Empty - 67 lbs. (30.39 kg) LCD Deployed Weight 745 lbs. (338 kg.) Fill with 81.24 gallons of water (307.5 L)
Pin Weight	1.8 lbs. (0.82 kg)
Wall Thickness	.25 +/- 20% (0.635 cm)
Retroreflective Sheeting	Striped sheeting in engineer grade or high intensity prismatic grade
Color	Orange and white

Use a Drum Bung/Plug Wrench to fit 3/4" and 2" bungs for removal and tightening of drain plug.

Available for purchase
Part # HYD-WRENCH



Optional fencing replaces connector pins

(Note: Hydrocade With Fencing Has Not Been MASH Tested)

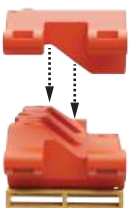

Compact Stacking

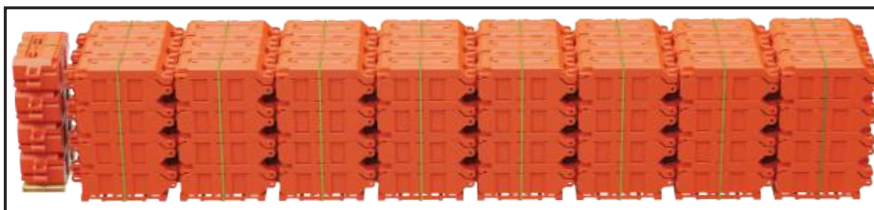

200 Units in 53' Truck

This device is not a barrier and should not be used where a re-directive device is required or desired.

Patents Pending
MADE IN THE USA